

DMN-WESTINGHOUSE

- Maximum protection against product degradation
- High filling efficiency
- Large air vent openings
- Robust construction
- Available with direct drive or chain driven
- Flanges drilled in accordance with PN 10, ANSI 150 lbs and JIS



GL Granular valves

DMN-WESTINGHOUSE GL valves are specially designed for gravity feeding and pneumatically conveying granular products. The configuration of the body and rotor has been developed specifically to minimise degradation whilst retaining the best possible pocket filling efficiency.

GL valves come in 5 sizes, covering a capacity range from approximately 5 to 79 liters per revolution at 100 % filling.

Product information

Three different body configurations are available: all stainless steel, stainless steel body with aluminium end covers and all aluminium. The aluminium configuration is anodised.

The full end disc rotor is made of 316 stainless steel. The end covers have outriggered ballbearings and the shaft is sealed with gland packings. The construction of the inlet minimises chopping of the product.

Standard models are suitable for handling products up to a temperature of 150 °C and a maximum pressure difference of 1.5 bar. Other options are available on request.

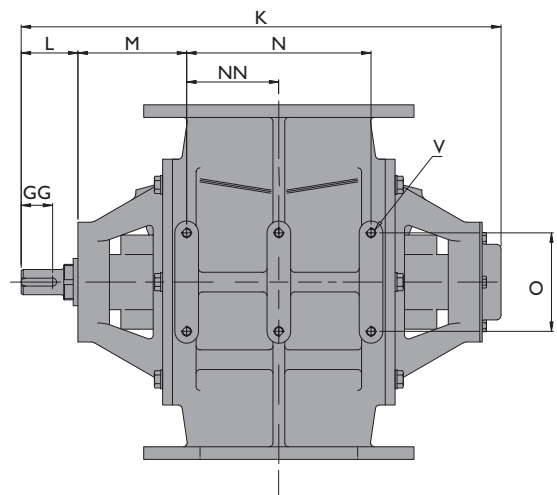
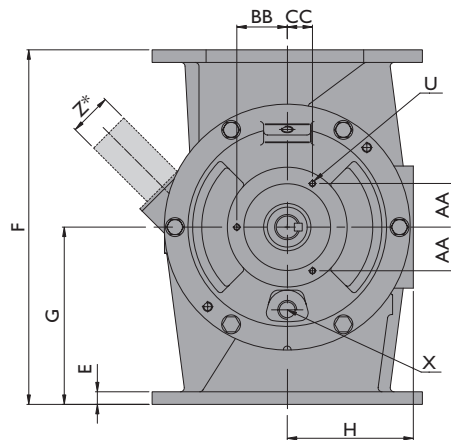
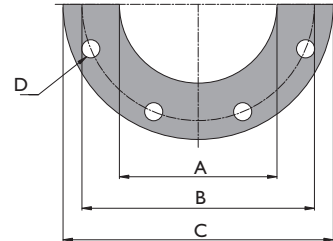
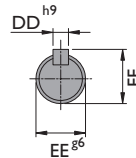
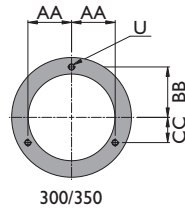

DMN-WESTINGHOUSE have been designing and manufacturing rotary valves, diverter valves and other related components for the bulk solids handling industry for more than 30 years. Offering tailor made solutions for chemical, food, plastics and pharmaceutical industries, DMN-WESTINGHOUSE products are distributed worldwide.

Besides an extensive range of standard components, we supply USDA approved sanitary versions and explosion-proof models.

An extensive network of subsidiaries, distributors and representatives ensures a high level of service and support all over the world.

Type GL	Ltr/rev	DIN			ANSI			E	F	G	H	K	L	M	N	NN	O
		ØA	ØB	D	ØC	ØB	D										
150	5	150	240	8XØ23	285	241.3	8XØ22.2	12	360	180	130	524	60	125	190	—	100
200	10	200	295	8XØ23	343	298.4	8XØ22.2	16	450	225	160	609	72	138	234	—	125
250	17.5	250	350	12XØ23	406	361.9	12XØ25.4	18	500	250	190	659	72	138	284	142	125
300	32	300	400	12XØ23	483	431.8	12XØ25.4	23	600	300	225	763	74	150	360	180	125
350	79	350	460	16XØ23	530	476.2	12XØ28.6	28	750	375	295	883	74	155	470	235	125

Type GL	U	V	X	Z	AA	BB	CC	DD	EE	FF	GG
150	3XM6	4XM10	3/8"	Ø48.3x2	37.1	52.5	37.1	8	30	33	35
200	3XM8	4XM12	1/2"	Ø60.3x2	55.4	64	32	10	32	35	43
250	3XM8	6XM12	1/2"	Ø76.1x2	55.4	64	32	10	32	35	43
300	3XM10	6XM12	3/4"	Ø88.9x2	73.6	85	42.5	10	38	41	44
350	3XM10	6XM12	3/4"	Ø88.9x2	73.6	85	42.5	10	38	41	44

* Optie : Ontluchtingspijp
 Option : Vent pipe
 Option : Entluchtingsrohr
 Option : Tube de degazage
 Opcional : Tubo de aire de perdida
 Opzione : Tubo di sfatio

Head Office:
DMN Machinefabriek Noordwykerhout B.V.

P.O. Box 6, 2210 AA Noordwijkerhout, Holland
 Tel. +31 252 361 800 Fax +31 252 375 972
 E-mail: dmn@dmn-nwh.nl

Internet: www.dmn.info



© DMN - HOLLAND - 2002

Subsidiaries:
DMN U.K. Ltd.

Unit 1&2, Harris Road,
 Porte Marsh Industrial Estate
 Calne, Wiltshire, SN 11 9PT, U.K.
 Tel. +44 1249 818 400
 Fax +44 1249 818 410
 E-mail: dmn@dmnuk.com

DMN Schüttguttechnik GmbH

Rütgersstrasse 8
 D-21244 Buchholz i.d. Ndh, Germany
 Tel. +49 4181 931 40
 Fax +49 4181 931 490
 E-mail: dmn@dmn-schuettguttechnik.de

DMN Italia S.r.l.

Via Teresa Noce, 2
 20060 Pessano Con Bornago (MI), Italy
 Tel. +39 02 950 4747
 Fax +39 02 950 4775
 E-mail: dmn@dmnitaly.com

DMN Incorporated

3895 South Perkins Road, Suite 8
 Memphis, TN 38118, U.S.A.
 Tel. +1 901 360 1537
 Fax +1 901 360 0348
 E-mail: dmnfo@dmn-inc.com